

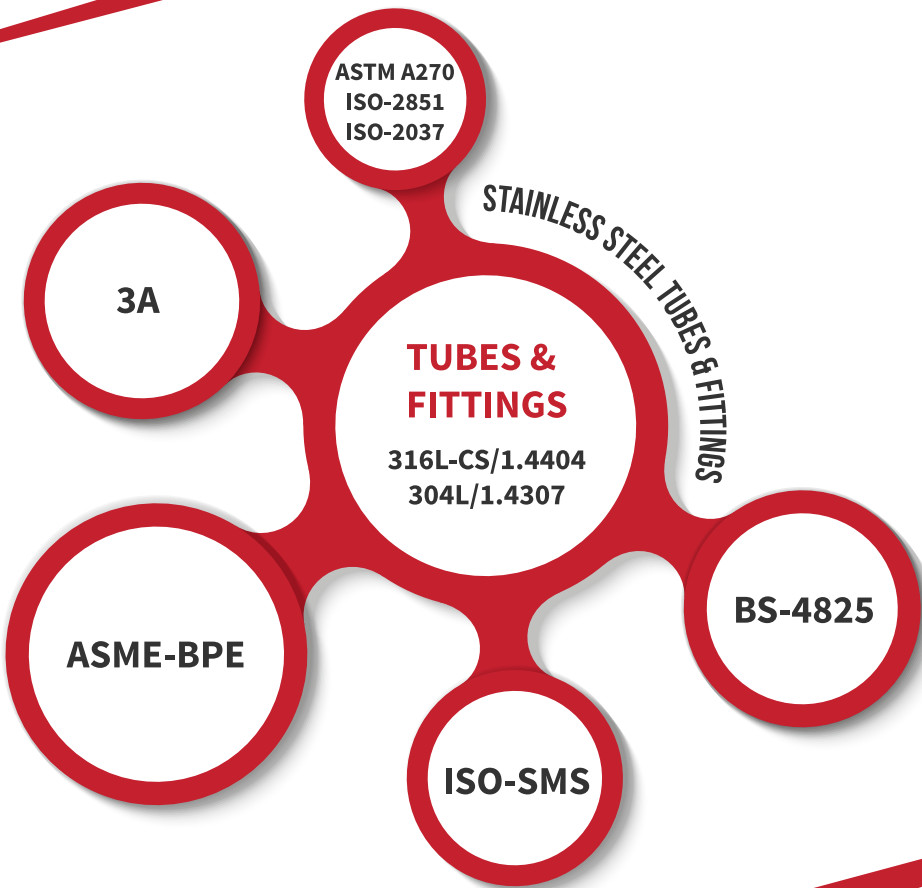

rensa
Positively Smooth



Stainless Steel

TUBES & FITTINGS

BRIGHT ANNEALED | MECHANICAL POLISHED | ELECTROPOLISHED

SANITARY | STERILE | HYGIENIC | ULTRA HIGH PURITY

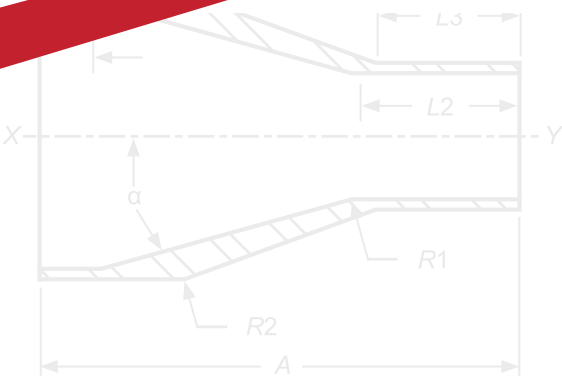

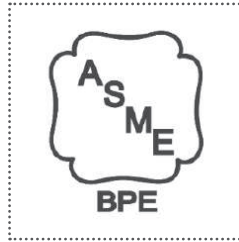

4-5	About Us
6-7	Commitment to quality
8-9	The rensa edge
10-11	Pharma & Biopharma
12-13	Healthcare & Cosmetics
14-15	Food & Beverages
16-17	Dairy
18-19	Product range
20	Fitting specifications
21	Fittings Ordering Information
22	3A fittings
23	BS & ISO fittings
24	SMS Union
25	BPE fitting Specification
26-27	BPE fittings
28-29	Chemical composition
30	Customer support
31	Customer list

ASTM A270 S2

- 3A
- BS 4825
- ISO-SMS
- ASME-BPE

ABOUT
US

17+ years of manufacturing

20,000 m² area

Global standards

Integrated production

Green process

Stainless Steel

TUBES & FITTINGS



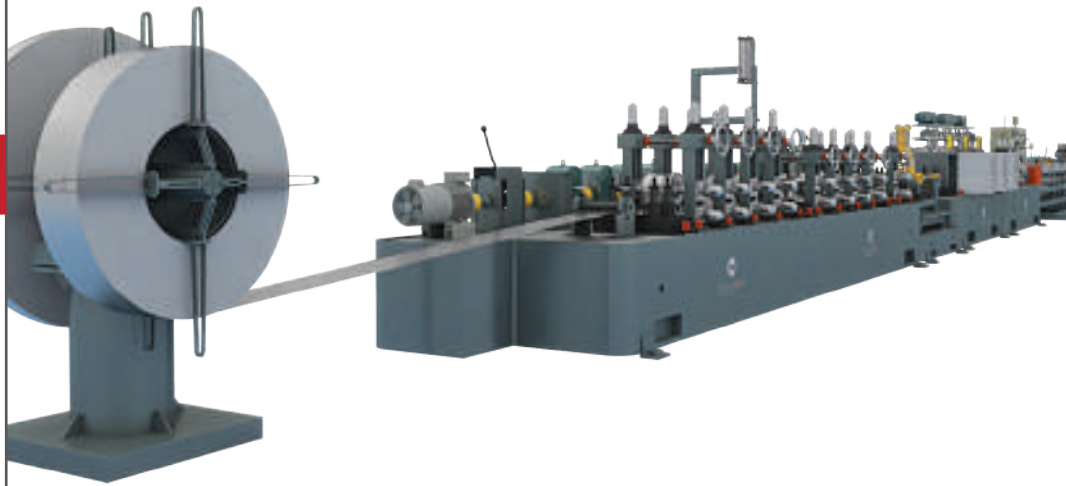

CAPABILITY & COMMITMENT ASSURED & DELIVERED

We manufacture high quality stainless steel electropolished tubes & fittings for *Pharmaceuticals, Bio-pharmaceuticals, Healthcare & Cosmetics, Food & Beverage and Dairy* industries.

For over 17 years, our commitment to **quality** and **customer service** standards has been unwavering.

Our mission is to provide hygienic and ultra-high purity stainless steel tubes & fittings for various *sterile, aseptic and sanitary* applications by complying with various global standards and specifications.

Its critically important to choose the right quality of tubes & fittings that get installed in the fluid transfer lines. Our technological know-how combines with our experience results in the production of stainless steel tubes of the highest quality comparable to the global standards.

QUALITY & CONSISTENCY ASSURED & DELIVERED

rensa comes with the commitment and assurance of the highest quality. Our stringent quality systems, technological know-how, innovation and our commitment to customer satisfaction are our key drivers.

Our manufacturing facility is certified with **ISO 9000-2015, PED 2014/68/EU** and **3-A sanitary certification** from USA. Every batch of tubes passes through a spectrum of required tests, that are both *destructive* and *non-destructive* types. Though a robust quality culture ensures we uphold our customers trust on our products, we continue to build and strengthen a culture of compliance & assurance, where every employee is trained to be vigilant and dedicated to the very highest standards of quality expected.

ABOUT US

Commitment, Quality & Trust



QUALITY CONSISTENCY DELIVERED

- Over 17 years of expertise & knowledge
- Fully integrated & automated production line
- Manufacturing capacity of 200,000 mtrs /month
- Full traceability with documentation support
- 20,000m² of manufacturing area
- Environmentally friendly bright annealing process
- ISO 9001-2015 certified
- 3A certified manufacturing facility
- PED 2014/68/EU & WO compliance



Rahul Ferromet & Engineering Pvt Ltd manufactures Hygienic & Ultra high Purity Stainless steel Tubes under brand name of **rensa** having its manufacturing facility at Jhagadia, Bharuch, Gujarat, India.

With over 17 years of manufacturing experience, the 20,000m² integrated manufacturing facility with over 100 committed and dedicated team of employees has a capacity to produce 100,000 mtrs / month of high quality stainless steel tubes with complete traceability and documentation.

Flowing High Purity

Assured Quality

Driven by Technology & Excellence,
fuelled by Commitment & Trust

Stainless Steel **TUBES & FITTINGS**

316 / 316L / 316L-CS / 1.4401 / 1.4404 / 1.4435, 304 / 304L / 1.4301 / 1.4307

We manufacture the finest quality of Stainless Steel tubes and fittings for the critical applications for **Pharma & Bio-Pharmaceuticals, Food & Beverages, Dairy and Healthcare & Cosmetics** in a fully automated European Tubes and Fittings production line under stringent quality control standards. The raw material sourced are of global standards.

GLOBAL STANDARDS

- Global certification & standards
- All tubes & fittings are controlled sulphur for better orbital welding
- All Fittings are mill faced and ready for orbital welding
- In-house facility for Electropolishing & Mechanical Polishing
- Environment friendly process

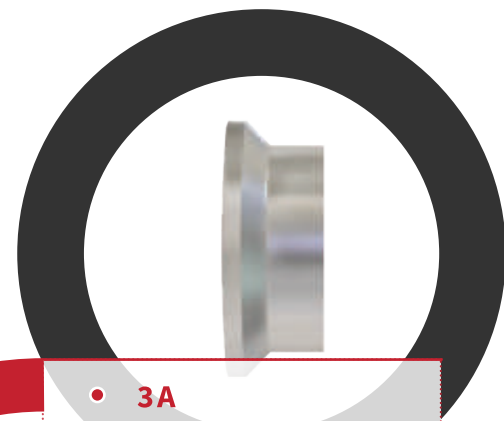

- **3A**
- **SMS 3008 & SS1145**
- **ISO 2851 & 2037**
- **BS 4825-1&2**
- **ASTM A270-S2**
- **ASME-BPE**



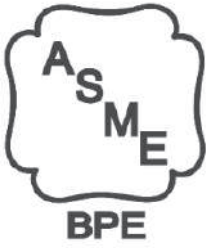

14 Quality Tests

Traceability

Controlled Sulphur

Bright Annealed Tubes

Advanced QC laboratory

100% hydro-tested tubes

KEY DIFFERENTIATORS

COMMITMENT TO QUALITY

Quality tests, Traceability, Certifications



CHEMICAL COMPOSITION TEST

Stringent, uncompromising quality standards sets us apart. We understand the critical nature of the fluids that our tubes carry. Every batch of tubes are subjected to rigorous test of both destructive and non-destructive in nature at every stage. This ensures only the qualified tubes pass on to the next stage. A well organized document plan ensures every tube, if required, can be tracked back to every stage in its manufacturing process and finally to its melt in the mill. A well trained and committed quality assurance and documentation team ensures strict adherence to laid out quality plan.

TUBE MANUFACTURING PROCESS

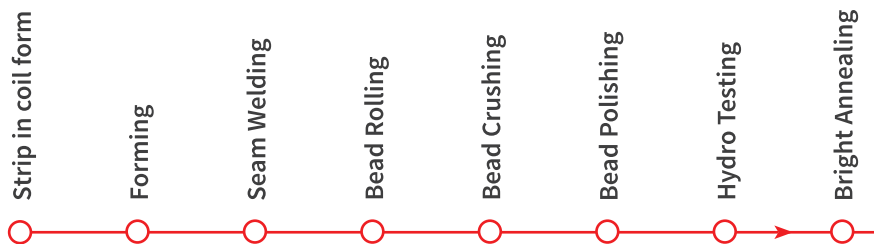
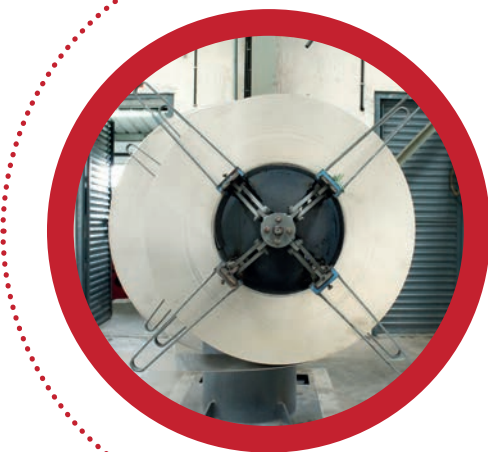

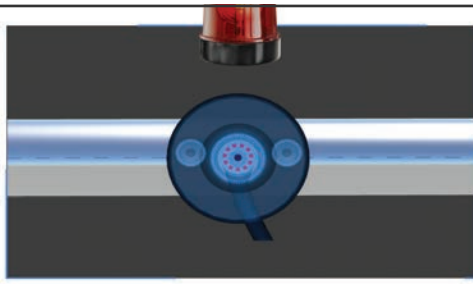

EDDY CURRENT TEST

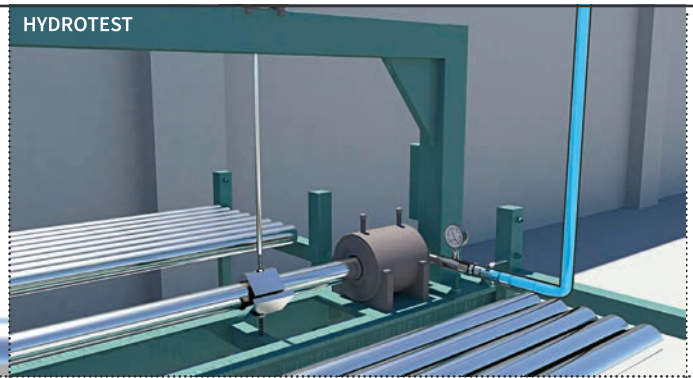

HYDROTEST

QUALITY TESTS

Our quality control laboratory and shop floor is equipped with modern machines that enable complete in-house testing of our tubes, using both destructive and non-destructive testing methods. Every batch of tubes undergoes stringent testing and qualifies to be certified only after it passes with required quality tests that include both destructive and non-destructive testing. Stringent parameters are laid down for each test and the results are documented and archived for traceability. All tests are carried out to meet and exceed the conforming standards requirements.



SURFACE FINISH MEASUREMENT

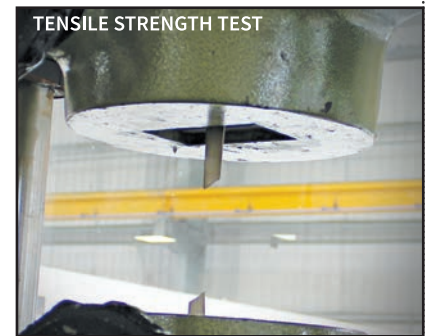

TENSILE STRENGTH TEST

- Eddy Current Testing
- Reverse Bend Test
- Hydro-test
- Tensile Strength Test
- Flaring Test
- Hardness Test
- Borescopy
- Flattening Test
- Reverse Flattening Test
- PMI test
- Grain Size Test
- Micro Test
- Surface Finish Test
- Inter Granular Corrosion Test

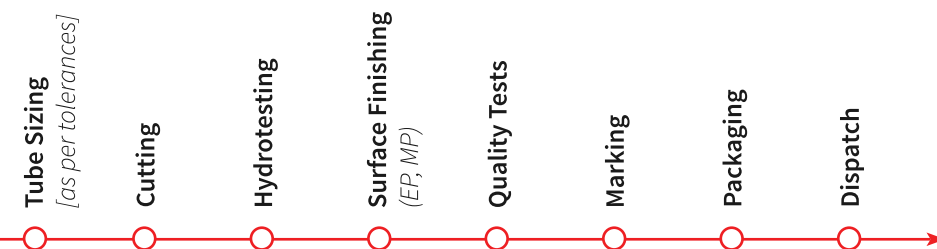

TUBE MANUFACTURING PROCESS



rensa ADVANTAGE

Get the **rensa** edge

14 Quality Tests

Traceability

Controlled Sulphur

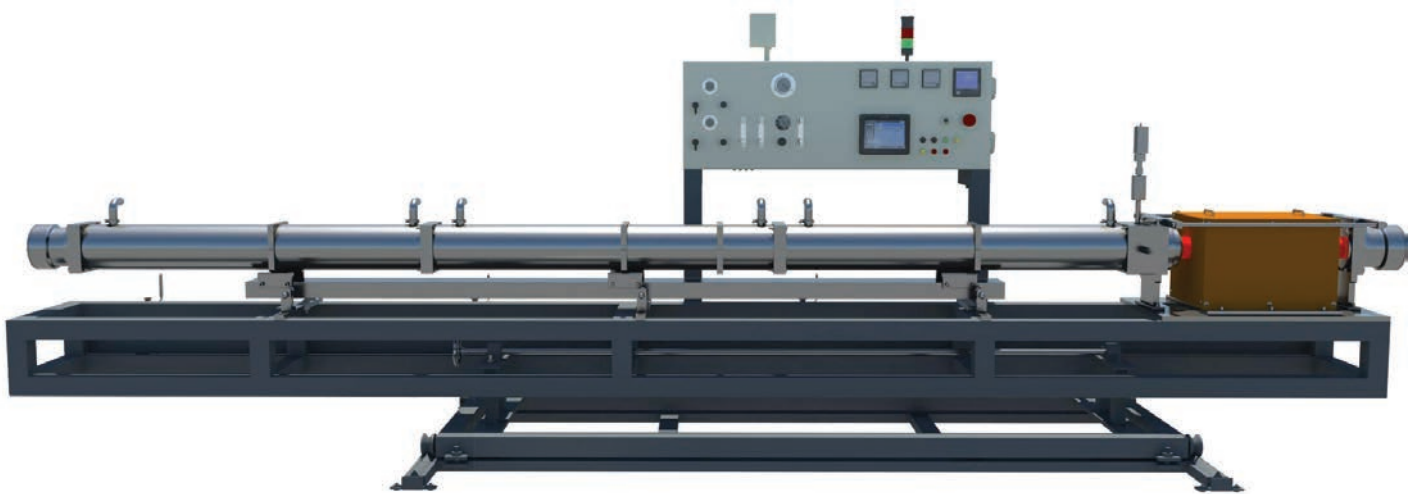

THE BRIGHT ANNEALING ADVANTAGE

Bright annealing is a solution-annealing operation performed in a vacuum or controlled atmosphere containing hydrogen, in order that oxidation is reduced to a minimum and the stainless steel tube surface remains relatively bright. Aside from a bright surface, the oxide layer is very thin after this type of annealing.

The tube is not pickled afterwards as this is not necessary – and pickling can also potentially damage the oxide layer. As pickling is avoided Bright annealed tubes almost retain their original parent material which helps

- Heating and cooling done at vacuum and hence no oxidation possibility
- No harmful chemicals used
- Tubes are ready to be electropolished without any intermediary finishing process requirement
- Environmentally friendly process
- Surface finish below $0.8 \mu\text{m}$ even on weld seam
- Assured thickness after the process
- Bright annealed surface has better resistance to pitting corrosion

us to get surface finish below $0.8 \mu\text{m}$ even on weld seam. As a result, with a cleaner and brighter appearance and a controlled inside-surface condition, bright annealed tubing has a much smoother surface which imbues the component with better resistance to pitting corrosion.

Overall, the bright annealed and surface –finished tube has considerably better corrosion resistance compared to the open annealed and pickled tubes.

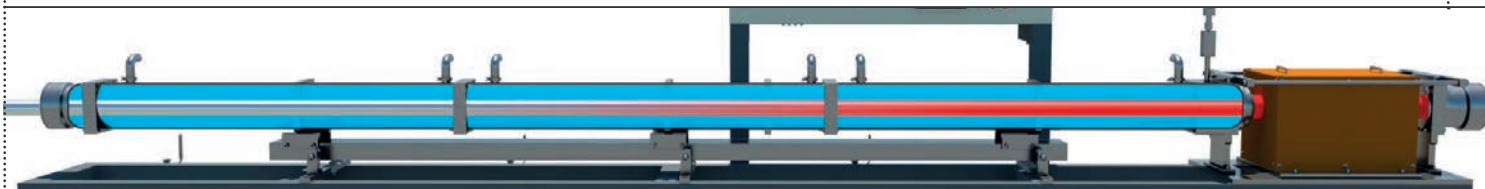



EIGHT MAJOR REASONS TO CONSIDER rensa TUBES & FITTINGS

○ TRACEABILITY

All tubes & fittings are marked with heat number on its surface. A well organized documentation plan ensures every tube can be tracked back to every stage of manufacturing. The fittings will be from the same source material as the tubes.

○ QUALITY RAW MATERIAL

The raw material sourced are of global standards.

○ EX-STOCK AVAILABILITY

We have ex-stock availability of almost all size grades and surface finishes. Option to order even small quantities as required.

○ GLOBAL STANDARDS

Our tubes conform to the applicable requirements of ASME-BPE, 3A, ISO-SMS, BS 4825, EN 10217-7 & ATSM A270 standards.

○ MANDATORY TESTS

Every batch of tubes undergo mandatory quality tests for assured quality in consistency as per Conforming standards requirements.

○ CERTIFICATIONS & ACCREDITATION

We manufacture tube for the global market. We are certified/ accredited with ISO 9001:2015, 3A 63-04, 3A 33-03, PED 2014/68/EU.

○ INHOUSE POLISHING

Only company in India to provide wide range of surface finish options as all surface finishing is done in-house, including electropolishing.

○ ASSURED THICKNESS

Since we manufacture both tubes and fittings, welding issues related thickness is avoided. This is a major concern if tubes and fittings are sourced from different vendors.

CERTIFICATIONS & ACCREDITATIONS

ISO 9001:2015



PED 2014/68/EU



ASME BPE

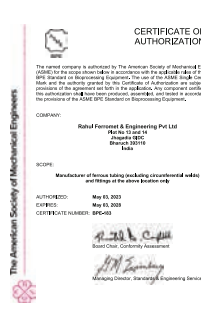

3A - TUBES



3A - FITTINGS

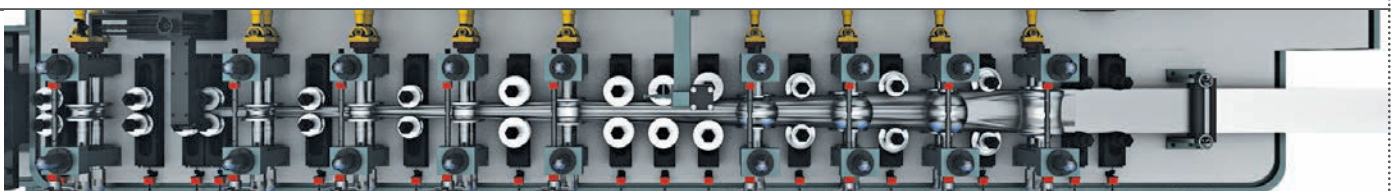
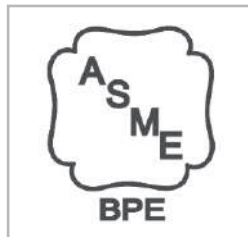

PHARMA

 BIO-PHARMA

 API

 R&D LABS



PHARMA & BIOPHARMA

Sanitary tubes for sterile applications

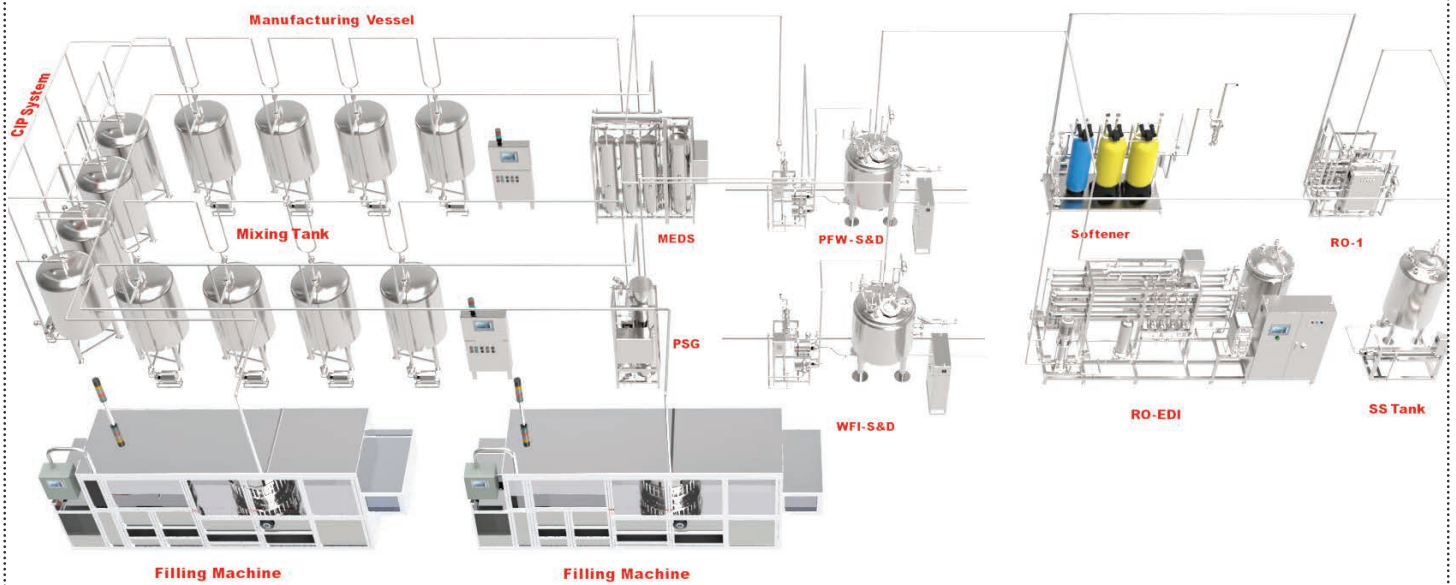

High quality surface finish, controlled sulphur and 100% traceability are a few of the many benefits that comes along with our tubes. For the pharmaceuticals and bio-pharmaceuticals, we offer tubes that are;

1. ASTM A 270 S2 compliant
2. As per ASME-BPE specifications
3. Controlled sulphur, low ferrite (EN 1.4404 / EN 1.4435)
4. Electropolished surface finish SF4- SF6
5. Mechanically polished surface finish from SF1-SF3
6. Complete traceability to raw material
7. Every batch of tubes undergo rigorous quality testing with required tests in both destructive and non-destructive, that ensures quality consistency. When it comes to quality, our standards assure it.





KEY APPLICATIONS AREAS

- PURIFIED WATER
- WFI
- CLEAN STEAM
- PROCESS
- CIP / SIP
- CLEAN UTILITIES

BUYING IN INDIA? SEVEN REASONS WHY YOU SHOULD CONSIDER *rensa* TUBES & FITTINGS

○ PAY IN INR

Eliminate cost escalations due to the forex fluctuations and banking formalities. Save on Bank charges, forex, agent commission etc.

○ ASSURED TIMELY DELIVERY

Eliminate custom clearance or shipping delays. You get the tubes when and where you want it delivered to your door steps.

○ SURFACE FINISH OPTIONS

Fittings are available with different surface finish options. All surface finish operations are inhouse including electropolishing.

○ ORDER SMALL QUANTITIES

No need to order in bulk. Save on inventory and handling costs as you order as much as you require.

○ EP 6.1 MTRS TUBES

We ship 6.1 Mtrs EP tubes whereas locally NON - EP imported tubes are electropolished in 3 mtrs length. Savings on transportation cost accrued due EP transportation.

○ SHORTER LEAD TIMES

A fully automated line and ex-stock inventory enables us to deliver tubes shorter lead times.

○ FACTORY ACCEPTANCE TEST

FAT can be conducted before taking delivery. Not possible when you import. The cost of tube replacement, delivery issues are eliminated for good.

GRADE & SURFACE FINISH GUIDELINE FOR TUBES

GRADE & SURFACE FINISH				
APPLICATION	GRADE	SURFACE FINISH		FINISH VALUE
		ID	OD	Ra (µm)
Soft water	304 L / 1.4307, 316L / 1.4404	MP/EP	MP	< 0.5/0.38
Potable water/ Purified water / WFI/ Pure steam/ SIP	316L / 1.4404	EP	MP	0.38
CIP	316L / 1.4404	MP	MP	< 0.5
Process chemical	316L / 1.4404	BA/MP/EP	MP	< 0.8/0.5/0.38
Compressed air / GAS	304 L / 1.4307 316L / 1.4404	BA	MP	< 0.8

[1] 316L / 1.4404 is used when ozone is used in disinfection system [2] 304L / 1.4307 is resistant to crevice and pitting type corrosion when chloride concentration is up to 500 mg/l with free chlorine concentration up to 5 mg/l at room temperature. If temp >50 °C then use 316L/1.4404 [3] 316L / 1.4404 is used when chloride concentration is above 500 mg/l - 2000 mg/l with free chlorine concentration upto 5 mg/l. [4] 316L / 1.4404 is used when temperature is >50 °C



TOOTHPASTE

ORAL CARE

CREAMS

SHAMPOO

KEY
INDUSTRY
SEGMENTS

HEALTHCARE & COSMETICS

Sanitary tubes hygienic applications

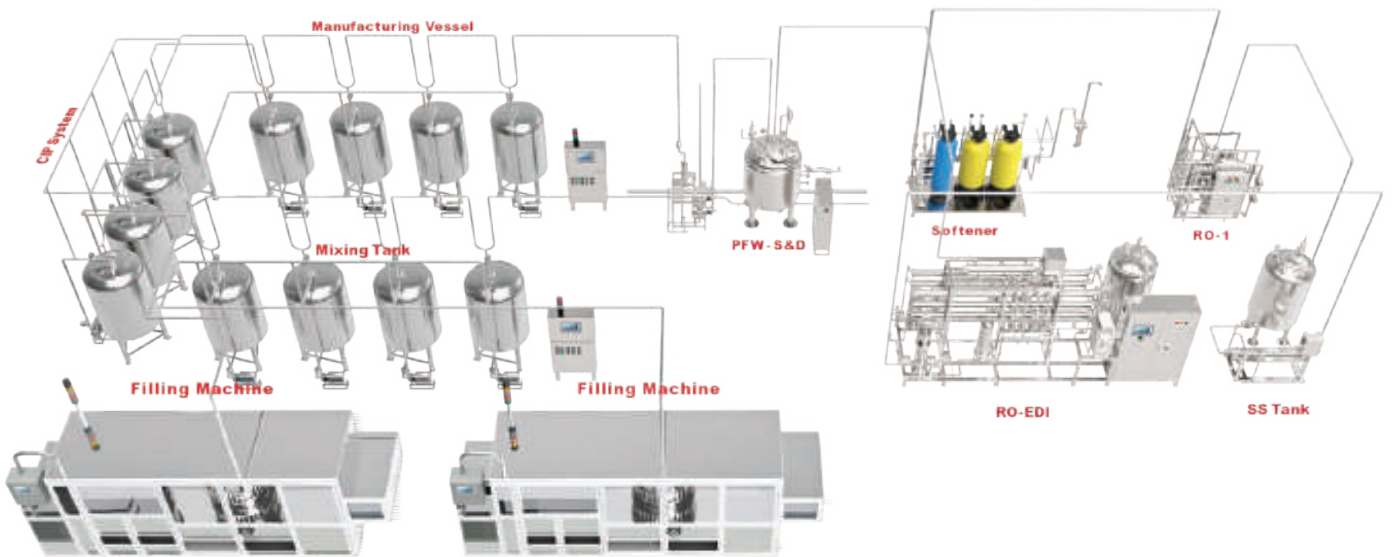



KEY APPLICATION AREAS

○ SOFT WATER ○ PURIFIED WATER ○ WFI ○ CLEAN STEAM ○ CIP / SIP ○ PROCESS ○ COMPRESSED AIR ○ GAS

The requirements of the Healthcare industry is no less than the Pharma / Bio-Pharma industry. Most of the time it is equivalent and in some instances more stringent. We offer SS316L tubes that are;

1. ASTM A 270 S2 compliant
2. Controlled sulphur, low ferrite (EN 1.4404 / EN 1.4435)
3. Electropolished
4. Complete traceability to raw material
5. Raw material sourced are of global standards.

Every batch of tubes undergo rigorous quality testing with over 14 tests in both destructive and non-destructive, that ensures quality consistency. Every tube comes with the heat number and with information to track it down through every process right to the melt of the ore from the mill. We are staffed with a experienced & trained quality assurance team with uncompromising approach towards quality. A well equipped and most modern laboratory, equipped with all the required destructive and non-destructive equipments ensures only the tubes with the right quality specifications are shipped out.



GRADE & SURFACE FINISH GUIDELINE FOR TUBES

GRADE & SURFACE FINISH				
APPLICATION	GRADE	SURFACE FINISH		FINISH VALUE
		ID	OD	Ra (µm)
Soft water	304 L / 1.4307, 316L / 1.4404	MP/EP	MP	< 0.5/0.38
Potable water/ Purified water / WFI/ Pure steam/ SIP	316L / 1.4404	EP	MP	0.38
CIP	316L / 1.4404	MP	MP	< 0.5
Process chemical	316L / 1.4404	BA/MP/EP	MP	< 0.8/0.5/0.38
Compressed air / GAS	304 L / 1.4307 316L / 1.4404	BA	MP	< 0.8

[1] 316L / 1.4404 is used when ozone is used in disinfection system [2] 304L / 1.4307 is resistant to crevice and pitting type corrosion when chloride concentration is up to 500 mg/l with free chlorine concentration up to 5 mg/l at room temperature. If temp >50 °C then use 316L/1.4404 [3] 316L / 1.4404 is used when chloride concentration is above 500 mg/l - 2000 mg/l with free chlorine concentration upto 5 mg/l. [4] 316L / 1.4404 is used when temperature is >50 °C

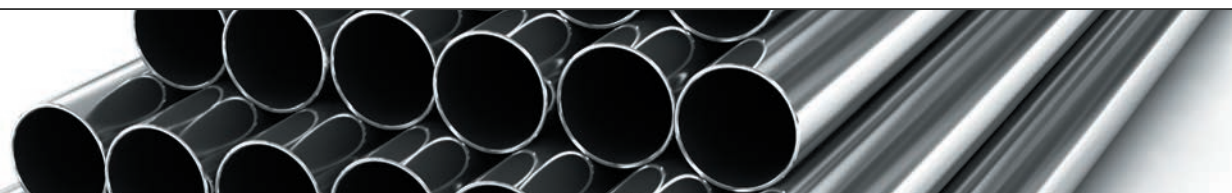

AERATED BEVERAGES

FRUIT JUICES

PROCESSED FOOD

NON-CARBONATED DRINKS



FOOD & BEVERAGES

Sanitary tubes for hygienic applications

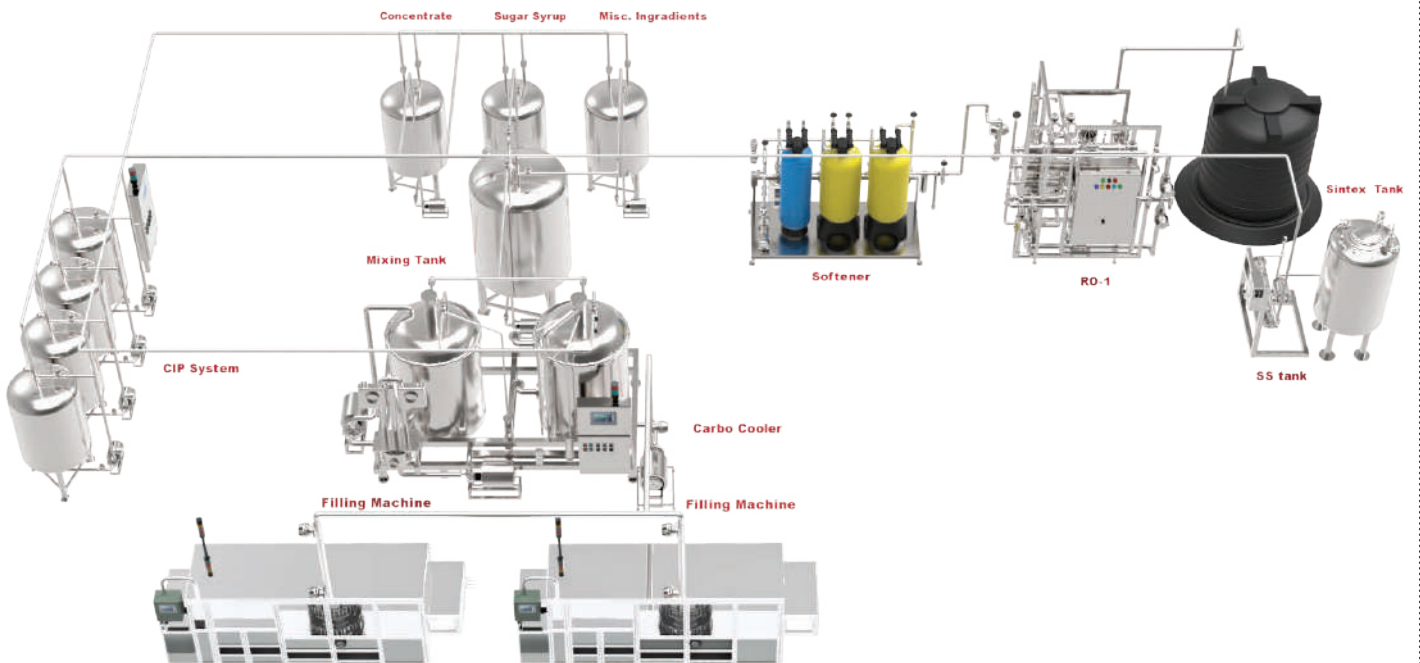



KEY APPLICATIONS AREAS

- PRODUCT/PROCESS
- TREATED WATER
- CLEAN STEAM
- CIP / SOFTWATER
- CHILLED WATER
- COMPRESSED AIR

We are one of the leading suppliers for tubes in the Food & Beverages industry. Our tubes are backed with years of our experience working with the beverages & breweries. We understand the requirement of the F&B industry better. The quality of the inner surface finish of the tube is very critical, when it comes to the transfer of aerated drinks, Fruit juices, Beer, wine etc. Be it the process lines, CIP / SIP lines, we have the right tubes that fit. Our in-house and proprietary process of electropolishing ensures a very high internal surface finish of the highest quality ($R_a < 0.38 \mu m$)

CONTROLLED SULPHUR TUBES

Controlling Sulphur content in the material is very critical when it comes to orbital welding. Both high and low sulphur in the tubes lead to unacceptable weld quality. Our range of tubes with EN 1.4404 & 1.4435 that comes with controlled sulphur range from 0.005 - 0.017, an ideal fit for orbital welding and this application.



GRADE & SURFACE FINISH GUIDELINE FOR TUBES

GRADE & SURFACE FINISH						
APPLICATION	GRADE	SURFACE FINISH		FINISH VALUE R_a (μm)		FINISH VALUE Grit
		ID	OD	ID	OD	ID
Product / Process (Carbonated)	304 L / 1.4307	MP	MP	< 0.5	< 0.8	> 180
Product / Process (Fruit based, Non-carbonated)	316L / 1.4404	MP/EP	MP	< 0.5/0.38	< 0.8	> 180/240
CIP / Soft water	316L / 1.4404	BA/MP	MP	< 0.8/0.5	< 0.8	> 150/180
Treated water	304L/1.4307, 316L / 1.4404	MP	MP	< 0.5	< 0.8	> 180
Chilled water / Compressed air	304L/ 1.4307, 316L/1.4404	BA	MP	< 0.8	< 0.8	> 150

[1] 316L / 1.4404 is used when ozone is used in disinfection system [2] 304L / 1.4307 is resistant to crevice and pitting type corrosion when chloride concentration is up to 500 mg/l with free chlorine concentration up to 5 mg/l at room temperature. If temp >50 °C then use 316L/1.4404 [3] 316L / 1.4404 is used when chloride concentration is above 500 mg/l - 2000 mg/l with free chlorine concentration upto 5 mg/l. [4] 316L / 1.4404 is used when temperature is >50 °C



DAIRY
MILK POWDER
CHEESE
MILK PRODUCTS

KEY
INDUSTRY
SEGMENTS

DAIRY

Sanitary tubes for the Dairy industry

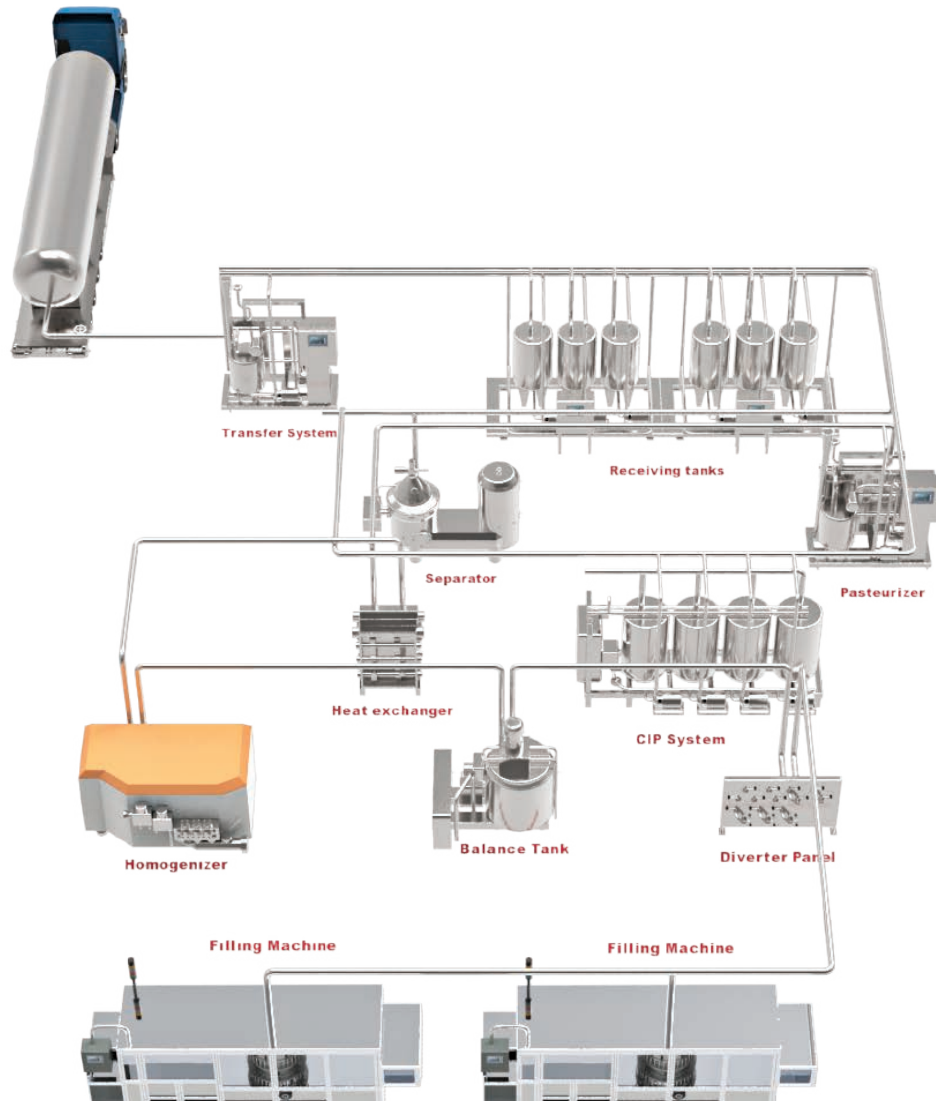



KEY APPLICATIONS AREAS

- MILKING SYSTEMS
- PROCESS
- CIP
- WATER
- CHILLED WATER
- COMPRESSED AIR

rensaTUBES are manufactured with Bright Annealing Technology instead of conventional open furnace Solution Annealing & Pickling method. Pickling is done with very harsh chemicals which damages the tube surface and also harmful to environment. As compared to Pickled tubes Bright annealing process gives very minimum level of oxidation on surface,

provides relatively much more brighter tube surface and maintain inside tube surface finish below 0.8 µm even on welding seam. As a result, with a cleaner and brighter appearance and a controlled inside-surface condition, bright annealed tubing has a much smoother surface which imbues the component with better resistance to pitting corrosion.



GRADE & SURFACE FINISH GUIDELINE FOR TUBES

GRADE & SURFACE FINISH						
APPLICATION	GRADE	SURFACE FINISH		FINISH VALUE Ra (µm)		FINISH VALUE Grit
		ID	OD	ID	OD	ID
Milk transfer	304L / 1.4307	MP/EP	MP	< 0.5/0.38	< 0.8	>180/240
Process	304L / 1.4307	MP/EP	MP	< 0.5/0.38	< 0.8	>180/240
CIP system [cleaning solution]	304L / 1.4307	BA/MP	MP	< 0.8/0.5	< 0.8	>150/180
Auto / Manual milking systems	304L / 1.4307	BA/MP	MP	< 0.8/0.5	< 0.8	>150/180
Water/Chilled water /Compressed air	304L / 1.4307 316L / 1.4404	BA	MP	< 0.8	< 0.8	>150

[1] 316L / 1.4404 is used when ozone is used in disinfection system [2] 304L / 1.4307 is resistant to crevice and pitting type corrosion when chloride concentration is up to 500 mg/l with free chlorine concentration up to 5 mg/l at room temperature. If temp >50 °C then use 316L/1.4404 [3] 316L / 1.4404 is used when chloride concentration is above 500 mg/l - 2000 mg/l with free chlorine concentration upto 5 mg/l. [4] 316L / 1.4404 is used when temperature is >50 °C



TUBES

- 3A 33
- ATSM A270
- ASME-BPE
- EN 10217-7

ASME-BPE

BS-4825-2, 3

ISO-2851

FITTINGS

STANDARDS

PRODUCT RANGE

High quality stainless steel sanitary tubes

	DIAMETER & THICKNESS		
	SIZE (inch)	OD (mm)	THK (mm)
3A	1/2	12.70	1.65
	3/4	19.05	1.65
	1	25.40	1.65
	1 1/2	38.10	1.65
	2	50.80	1.65
	2 1/2	63.50	1.65
	3	76.20	1.65
	4	101.60	2.11

SPECIFICATIONS & LENGTH	
Standards	ASTM A 270 compliant & EN 10217 - 7
Material	304 / 304 L / 1.4301 / 1.4307 316 L / 1.4404
Length	6.1 mtrs (20 ft)
Surface finish	Mill finish: - Bright Annealed (ID/OD) - Mechanical Polished (ID/OD) - Electropolished (ID)

	DIAMETER & THICKNESS		
	SIZE (inch)	OD (mm)	THK (mm)
BS-4825	1/2	12.70	1.20
	3/4	19.05	1.20
	1	25.40	1.60
	1 1/2	38.10	1.60
	2	50.80	1.60
	2 1/2	63.50	1.60
	3	76.20	1.60
	4	101.60	2.00

SPECIFICATIONS & LENGTH	
Standards	ASTM A 270 compliant & EN 10217 - 7
Material	304 / 304 L / 1.4301 / 1.4307 316 L / 1.4404
Length	6.1 mtrs (20 ft)
Surface finish	Mill finish: - Bright Annealed (ID/OD) - Mechanical Polished (ID/OD) - Electropolished (ID)

	DIAMETER & THICKNESS		
	SIZE (inch)	OD (mm)	THK (mm)
ISO-SMS	1	25.00	1.20
	1 1/2	38.00	1.20
	2	51.00	1.20
	2 1/2	63.50	1.60
	3	76.10	1.60
	4	101.60	2.00

SPECIFICATIONS & LENGTH	
Standards	ASTM A270 compliant & EN 10217 - 7
Material	304 / 304 L / 1.4301 / 1.4307 316 L / 1.4404
Length	6.1 mtrs (20 ft)
Surface finish	Mill finish: - Bright Annealed (ID/OD) - Mechanical Polished (ID/OD) - Electropolished (ID)

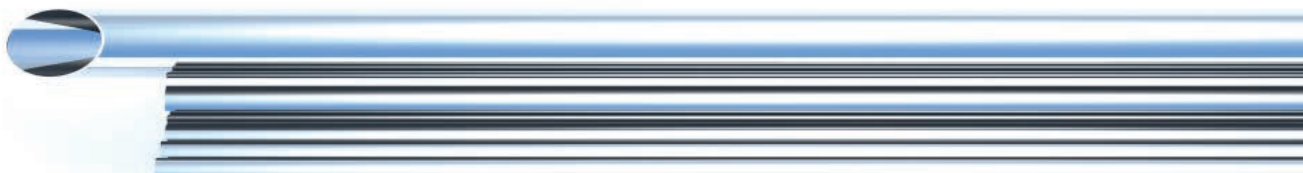



PRODUCT RANGE

High quality stainless steel sanitary tubes

ASME-BPE	DIAMETER & THICKNESS			SPECIFICATIONS & LENGTH		
	SIZE (inch)	OD (mm)	THK (mm)	Standards	ASTM A 270 S2 compliant ; EN 10217-7	
	1/2	12.70	1.65	Material	316L / 1.4404 / 1.4435	
	3/4	19.05	1.65	Length	6.1 mtrs (20 ft)	
	1	25.40	1.65	Surface finish	Mill finish: - Bright Annealed (ID/OD) - Mechanical Polished as per SF1-SF3 (ID/OD) - Electropolished as per SF4-SF6 (ID)	
	1 ½	38.10	1.65			
	2	50.80	1.65			
	2 ½	63.50	1.65			
	3	76.20	1.65			
4	101.60	2.11				

SURFACE FINISH ASME-BPE	MECHANICALLY POLISHED			MECHANICALLY POLISHED & ELECTROPOLISHED		
	SURFACE DESIGNATION	Ra Max		SURFACE DESIGNATION	Ra Max	
		µ-in	µm		µ-in	µm
	SF1	20	0.51	SF4	15	0.38
SF2	25	0.64	SF5	20	0.51	
SF3	30	0.76	SF6	25	0.64	

GRIT / Ra	SURFACE FINISH COMPARISON [GRIT/Ra]		
	GRIT	Ra Max	
		µ-in	µm
	150	27 - 32	0.68 - 0.80
	180	16 - 23	0.46 - 0.58
240	14 - 18	0.34 - 0.46	
320	8 - 10	0.21 - 0.25	

Note:

Grit : Measures the number of scratches per linear inch of abrasive pad. Higher numbers indicate a smoother surface.

Ra : Known as the arithmetic mean, this measurement represents the average of all peaks and valleys. Lower numbers indicates a smooth finish

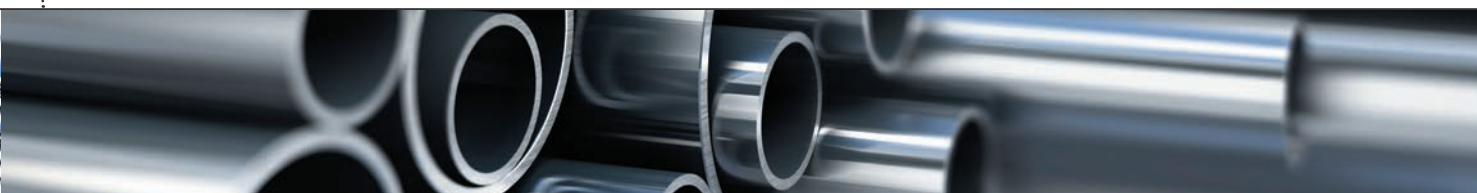

FITTING SPECIFICATIONS

Sanitary Stainless Steel

Bright Annealed

Advanced QC laboratory

Fittings from Same
Parent MaterialKEY
DIFFERENTIATORS

○ DIMENSIONS & TOLERANCES

Wall thickness tolerances are set and maintained to match-up ASTM A269/270 & ISO, BS requirements. After forming, all tubular fittings undergo a resizing operation to ensure dimensional accuracy before facing and finishing operations. The sizing technique employed varies according to the shape and dimension of the specific fitting.

○ CONTROLLED METALLURGY:

Excellent batch-to-batch consistency leads to excellent consistency of orbital welds.

○ SURFACE FINISH:

rensa offers a wide variety of surface finishing

- Mechanically polished
- Electro-Polished - special on request
- Bright Annealed

○ CLEANING:

All rensa stainless steel parts are passivated in a light acid solution to ensure that components are free of contaminants such as burrs, stains, oil, loose particles etc. At a final stage, the fittings are double-rinsed using hot DI water.

○ MARKING:

Each fitting is marked to show the following

- Material type
- Manufacturer's brand
- Conforming specification e.g. BS, 3A, BPE
- Product size
- Heat No.

Note: In some instances, due to the size of the component this information may be presented in the form of code.

○ PACKAGING:

Each fitting is capped or skin-packed on cardboard.

○ DOCUMENTATION:

Full Material Test Reports (MTRs) are finished on customer request with the finished goods, or via interactive internet website, using a special private code.



FITTINGS ORDERING INFORMATION

Sanitary Stainless Steel

Weld Fittings and Clamp fittings are available in type TP 304L (1.4307) and TP 316L-CS (1.4404) Stainless Steel. These fittings are available in a variety of ID and OD surface finishing, each identified by a code.

Instructions for ordering are as follows:

Specify complete part name including standard, size, surface finish and material type.

ORDERING NUMBER EXAMPLE

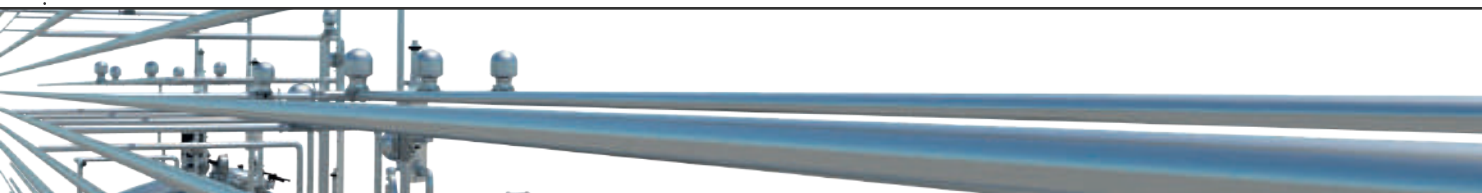
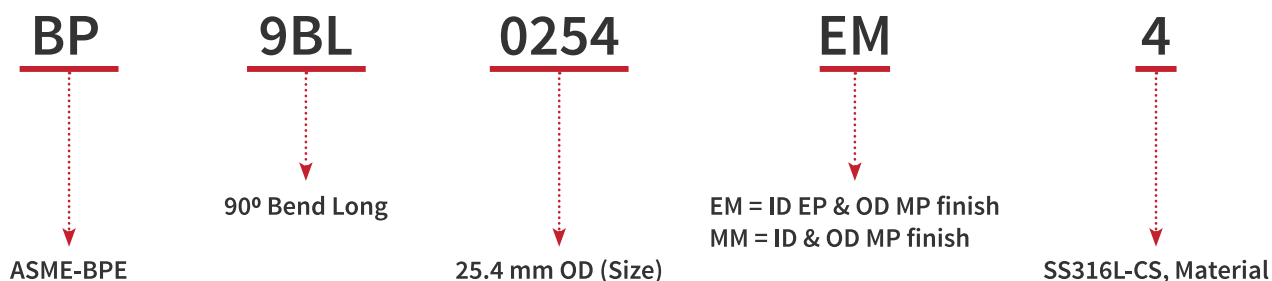
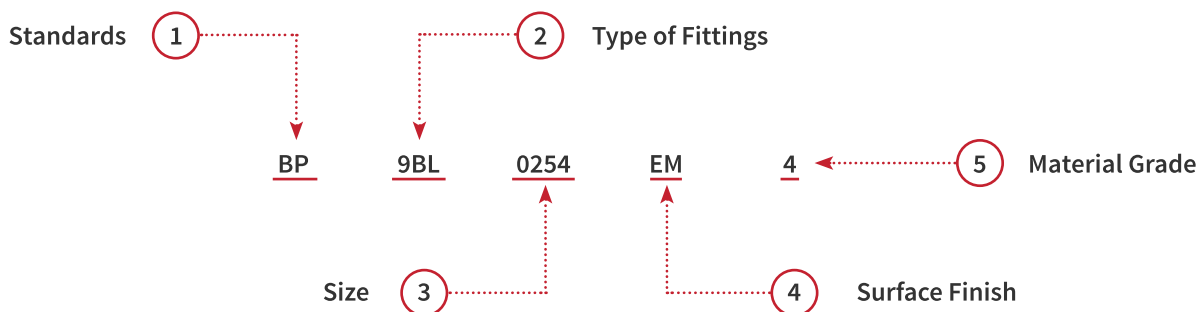
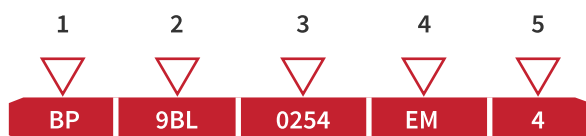

3A FITTINGS

90° BEND

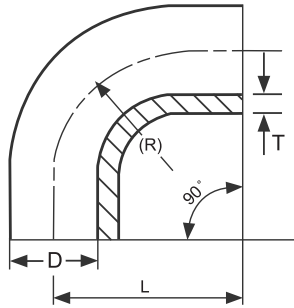

PART CODE	D (in)	T (mm)	D (mm)	L (mm)	R (mm)
3A9BL0127	1/2"	1.65	12.7	45.0	28.58
3A9BL0191	3/4"	1.65	19.05	58.5	28.58
3A9BL0254	1"	1.65	25.4	52.4	38.10
3A9BL0381	1-1/2"	1.65	38.1	74.6	57.20
3A9BL0508	2"	1.65	50.8	103.2	76.20
3A9BL0635	2-1/2"	1.65	63.5	131.8	95.30
3A9BL0762	3"	1.65	76.2	155.0	114.30
3A9BL1016	4"	2.11	101.6	195.0	152.40

BS & ISO FITTINGS

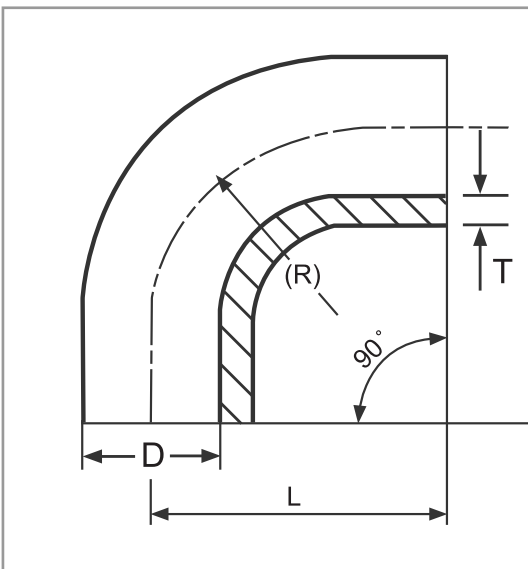

90° BEND as per BS 4825-2	PART CODE	D in	T mm	D mm	L mm	R mm
	BS9BL0254	1"	1.60	25.4	65	38.10
	BS9BL0381	1-1/2"	1.60	38.1	85	57.15
	BS9BL0508	2"	1.60	50.8	110	76.20
	BS9BL0635	2-1/2"	1.60	63.5	135	95.25
	BS9BL0762	3"	1.60	76.2	155	114.30
	BS9BL1016	4"	2.00	101.6	195	152.40

90° BEND as per ISO 2851	PART CODE	D mm	T mm	D mm	L mm	R mm
	IS9BL0250	25	1.20	25	65	37.50
	IS9BL0380	38	1.20	38	85	57.00
	IS9BL0510	51	1.20	51	110	76.50
	IS9BL0635	63.5	1.60	63.5	135	95.25
	IS9BL0761	76.1	1.60	76.1	155	114.15
	IS9BL1016	101.6	2.00	101.6	195	152.40

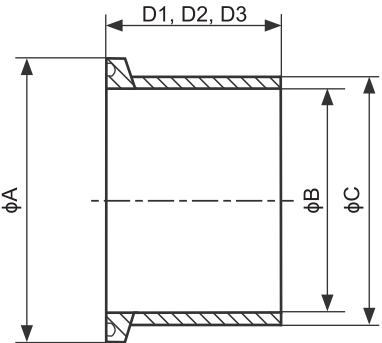

BS & ISO FITTINGS

CLAMPED FERRULE - LONG			PART CODE	NOMINAL SIZE (in)	A (mm)	B (mm)	C (mm)	D1 (mm)
	3AFL0127	1/2"	25.2	9.4	12.7	28.6		
	3AFL0191	3/4"	25.2	15.75	19.05	28.6		
	3AFL0254	1"	50.5	22.1	25.4	28.6		
	3AFL0381	1-1/2"	50.5	34.8	38.1	28.6		
	3AFL0508	2"	64	47.5	50.8	28.6		
	3AFL0635	2-1/2"	77.5	60.2	63.5	28.6		
	3AFL0762	3"	91	72.9	76.2	28.6		
	3AFL1016	4"	119	97.4	101.5	28.6		

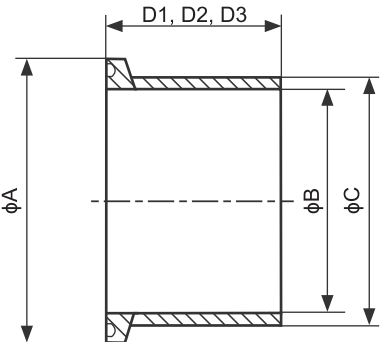
CLAMPED FERRULE - MEDIUM			PART CODE	NOMINAL SIZE (in)	A (mm)	B (mm)	C (mm)	D2 (mm)
	3AFM0127	1/2"	25.2	9.4	12.7	21.5		
	3AFM0191	3/4"	25.2	15.75	19.05	21.5		
	3AFM0254	1"	50.5	22.1	25.4	21.5		
	3AFM0381	1-1/2"	50.5	34.8	38.1	21.5		
	3AFM0508	2"	64	47.5	50.8	21.5		
	3AFM0635	2-1/2"	77.5	60.2	63.5	21.5		
	3AFM0762	3"	91	72.9	76.2	21.5		
	3AFM1016	4"	119	97.4	101.6	21.5		

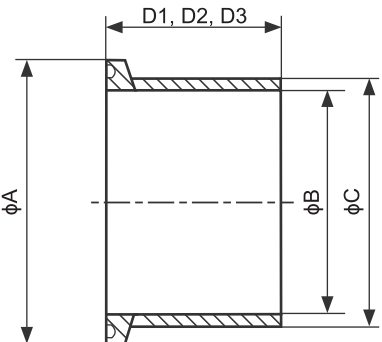
CLAMPED FERRULE - SHORT			PART CODE	NOMINAL SIZE (in)	A (mm)	B (mm)	C (mm)	D3 (mm)
	3AFS0127	1/2"	25.2	9.4	12.7	12.7		
	3AFS0191	3/4"	25.2	15.75	19.05	12.7		
	3AFS0254	1"	50.5	22.1	25.4	12.7		
	3AFS0381	1-1/2"	50.5	34.8	38.1	12.7		
	3AFS0508	2"	64	47.5	50.8	12.7		
	3AFS0635	2-1/2"	77.5	60.2	63.5	12.7		
	3AFS0762	3"	91	72.9	76.2	12.7		
	3AFS1016	4"	119	97.4	101.6	15.9		

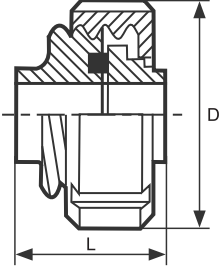

SMS UNION

UNION		PART CODE	NOMINAL SIZE (in)	D (mm)	L (mm)
		SMU0254	1"	51	24
		SMU0381	1-1/2"	74	31
		SMU0508	2"	84	31
		SMU0635	2-1/2"	100	35
		SMU0762	3"	114	36
		SMU1016	4"	154	49

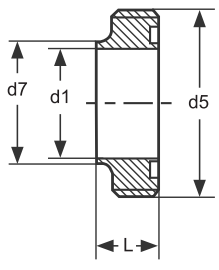
UNION - MALE PART		PART CODE	NOMINAL SIZE (in)	L (mm)	d1 (mm)	d7 (mm)	Rd.d5 (mm)
		SMU(M)0254	1"	15	22.6	25	40x1/6"
		SMU(M)0381	1-1/2"	20	35.6	38	60x1/6"
		SMU(M)0508	2"	20	48.6	51	70x1/6"
		SMU(M)0635	2-1/2"	24	60.3	63.5	85x1/6"
		SMU(M)0762	3"	24	72.9	76.1	98x1/6"
		SMU(M)1016	4"	35	97.6	101.6	132x1/6"

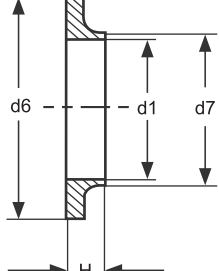
UNION - LINER		PART CODE	NOMINAL SIZE (in)	H (mm)	d1 (mm)	d7 (mm)	d6 (mm)
		SMU(L)0254	1"	7.5	22.6	25	35.5
		SMU(L)0381	1-1/2"	9	35.6	38	55
		SMU(L)0508	2"	9	48.6	51	65
		SMU(L)0635	2-1/2"	9	60.3	63.5	80
		SMU(L)0762	3"	10	72.9	76.1	93
		SMU(L)1016	4"	12	97.6	101.6	127

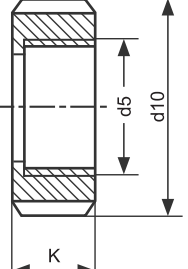
UNION - NUT		PART CODE	NOMINAL SIZE (in)	K (mm)	d10 (mm)	Rd.d5 (mm)
		SMU(N)0254	1"	20	51	40x1/6"
		SMU(N)0381	1-1/2"	25	74	60x1/6"
		SMU(N)0508	2"	26	84	70x1/6"
		SMU(N)0635	2-1/2"	30	100	85x1/6"
		SMU(N)0762	3"	32	114	98x1/6"
		SMU(N)1016	4"	30	150	132x1/6"

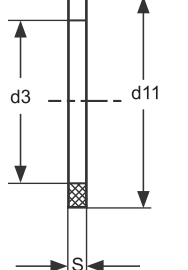
UNION - GASKET		PART CODE	NOMINAL SIZE (in)	S (mm)	d3 (mm)	d11 (mm)
		SMU(G)0254	1"	4	25	32
		SMU(G)0381	1-1/2"	4	38	48
		SMU(G)0508	2"	4	51	61
		SMU(G)0635	2-1/2"	4	63.5	73.5
		SMU(G)0762	3"	4	76.1	86
		SMU(G)1016	4"	4	101.6	114

ASME BPE FITTINGS SPECIFICATIONS

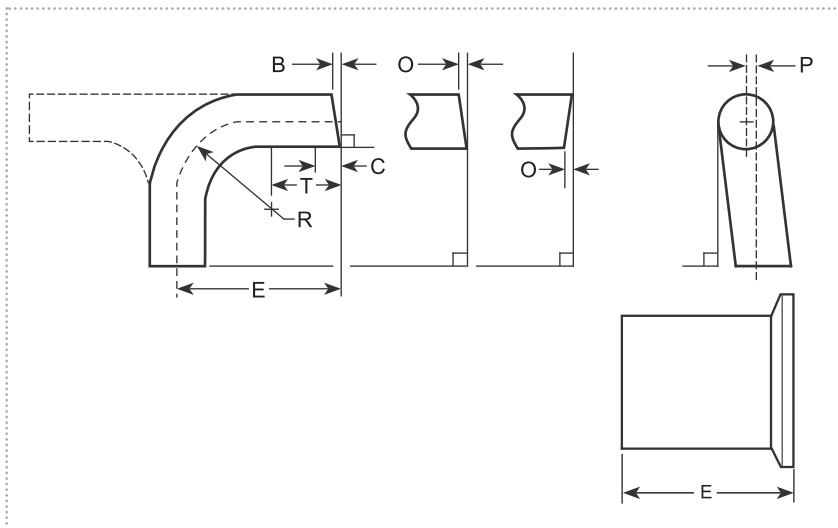
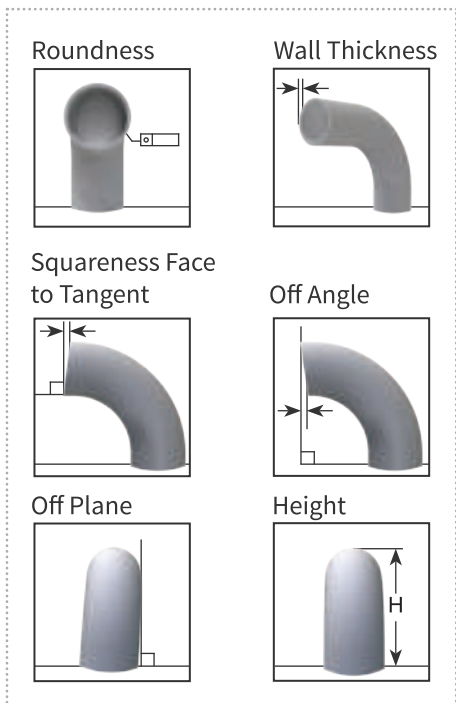

GENERAL NOTES:

- a. Tolerance on (E) end-to-end and center-to-end: 0.050 in. (1.27 mm).
- b. Tolerance for centerline radius (CLR) is ± 10% of the nominal dimension.

○ SURFACE FINISH:

Reference: ASME BPE-2019, SF 2.4.1 -1.

BPE SURFACE DESIGNATION	INSIDE SURFACE		
	Ra Maximum		SURFACE CONDITION
	(μ-in)	(μm)	
SF0			No finish requirement
SF1	20	0.51	Mechanically Polished [1]
SF2	25	0.64	Mechanically Polished [1]
SF3	30	0.76	Mechanically Polished [1]
SF4	15	0.38	Mechanically Polished [1] & Electropolished
SF5	20	0.51	Mechanically Polished [1] & Electropolished
SF6	25	0.64	Mechanically Polished [1] & Electropolished

[1] Or any other finishing method that meets the Ra max.

- **rensa** fittings guarantee the Ra in all internal surfaces, including bent areas where it is difficult to polish and difficult to measure.
- All Ra readings are taken across the lay, wherever possible.
- No single Ra reading shall exceed the Ra max. value in this table.
- Other Ra readings are available if agreed upon between owner/user and supplier, not to exceed values in this table.



ASME BPE FITTINGS

○ PRODUCT:

Stainless Steel fittings comply with ASME BPE standards.

○ SIZES:

Stainless Steel fittings are available in sizes 1/2" - 4" OD tube size.

○ MATERIAL:

Fittings are fabricated in AISI 316L Stainless Steel with sulfur content of 0.005-0.0017% achieving superior repeatability for automatic orbital welding process.

○ DIMENSIONS & TOLERANCES:

Dimensions as specified in ASME BPE Part DT-3-1

NOMINAL SIZE	O.D		WALL THICKNESS MECHANICAL POLISH (MP)		WALL THICKNESS ELECTROPOLISH (EP)		SQUARENESS FACE TO TANGENT, B		OFF ANGLE, 0	
	(in)	(in) (mm)	(in)	(mm)	(in)	(mm)	(in)	(mm)	(in)	(mm)
1/4	± 0.005	± 0.13	+0.003/-0.004	+0.08/-0.10	+0.003/-0.006	+0.08/-0.15	0.005	0.13	0.009	0.23
3/8	± 0.005	± 0.13	+0.003/-0.004	+0.08/-0.10	+0.003/-0.006	+0.08/-0.15	0.005	0.13	0.012	0.3
1/2	± 0.005	± 0.13	+0.005/-0.008	+0.13/-0.20	+0.005/-0.010	+0.13/-0.25	0.005	0.13	0.014	0.36
3/4	± 0.005	± 0.13	+0.005/-0.008	+0.13/-0.20	+0.005/-0.010	+0.13/-0.25	0.005	0.13	0.018	0.46
1	± 0.005	± 0.13	+0.005/-0.008	+0.13/-0.20	+0.005/-0.010	+0.13/-0.25	0.008	0.20	0.025	0.64
1 1/2	± 0.008	± 0.20	+0.005/-0.008	+0.13/-0.20	+0.005/-0.010	+0.13/-0.25	0.008	0.20	0.034	0.86
2	± 0.008	± 0.20	+0.005/-0.008	+0.13/-0.20	+0.005/-0.010	+0.13/-0.25	0.008	0.20	0.043	1.09
2 1/2	± 0.010	± 0.25	+0.005/-0.008	+0.13/-0.20	+0.005/-0.010	+0.13/-0.25	0.010	0.25	0.054	1.37
3	± 0.010	± 0.25	+0.005/-0.008	+0.13/-0.20	+0.005/-0.010	+0.13/-0.25	0.016	0.41	0.068	1.73
4	± 0.005	± 0.38	+0.008/-0.010	+0.20/-0.25	+0.008/-0.012	+0.20/-0.30	0.016	0.41	0.086	2.18
6	± 0.030	± 0.76	+0.015/-0.015	+0.38/-0.38	+0.015/-0.017	+0.38/-0.43	0.030	0.76	0.135	3.43

EQUIVALENT ANGLE (FOR O)	OFF PLANE, P		CENTER LINE RADIUS (CLR), R	
(in)	(in)	(mm)	(in)	(mm)
2.1	0.030	0.76	0.563	14.30
1.8	0.030	0.76	1.125	28.58
1.6	0.030	0.76	1.125	28.58
1.4	0.030	0.76	1.125	28.58
1.4	0.030	0.76	1.500	38.10
1.3	0.050	1.27	2.250	57.15
1.2	0.050	1.27	3.000	76.20
1.2	0.050	1.27	3.750	95.25
1.3	0.050	1.27	4.500	114.30
1.2	0.060	1.52	6.000	152.40
1.3	0.060	1.52	9.000	228.60

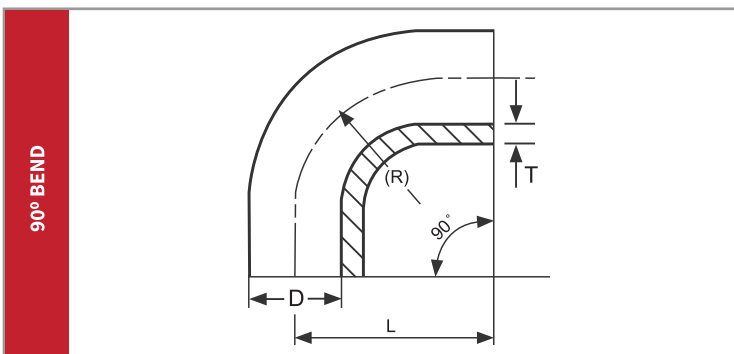

PART CODE	D (in)	T (mm)	D (mm)	L (mm)	R (mm)
BP9BL0127	1/2"	1.65	12.7	76.2	28.58
BP9BL0191	3/4"	1.65	19.05	76.2	28.58
BP9BL0254	1"	1.65	25.4	76.2	38.10
BP9BL0381	1-1/2"	1.65	38.1	95.25	57.15
BP9BL0508	2"	1.65	50.8	120.65	76.20
BP9BL0635	2-1/2"	1.65	63.5	139.7	95.25
BP9BL0762	3"	1.65	76.2	158.75	114.30
BP9BL1016	4"	2.11	101.6	203.2	152.40

ASME BPE FITTINGS

TEE

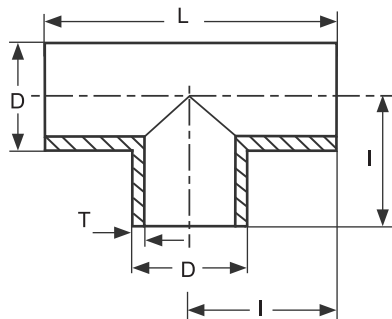

PART CODE	D (in)	T (mm)	D (mm)	L (mm)	I (mm)
BPTL0127	1/2"	1.65	12.7	95.25	47.63
BPTL0191	3/4"	1.65	19.05	101.6	50.8
BPTL0254	1"	1.65	25.4	107.90	53.98
BPTL0381	1-1/2"	1.65	38.1	120.66	60.33
BPTL0508	2"	1.65	50.8	146.06	73.03
BPTL0635	2-1/2"	1.65	63.5	158.76	79.38
BPTL0762	3"	1.65	76.2	171.46	85.73
BPTL1016	4"	2.11	101.6	209.56	104.78

REDUCING TEE

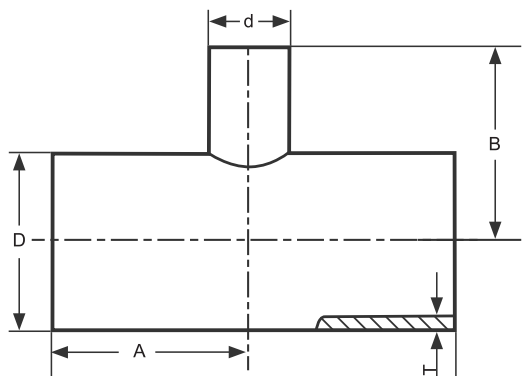

PART CODE	D x d (in)	D (mm)	d (mm)	A (mm)	B (mm)
BPRTL01910127	3/4"x1/2"	19.05	12.70	50.80	50.80
BPRTL02540127	1"x1/2"	25.40	12.70	53.98	53.98
BPRTL02540191	1"x3/4"	25.40	19.05	53.98	53.98
BPRTL03810127	1-1/2"x1/2"	38.10	12.70	60.33	60.33
BPRTL03810191	1-1/2"x3/4"	38.10	19.05	60.33	60.33
BPRTL03810254	1-1/2"x1"	38.10	25.40	60.33	60.33
BPRTL05080127	2"x1/2"	50.80	12.70	73.03	66.68
BPRTL05080191	2"x3/4"	50.80	19.05	73.03	66.68
BPRTL05080254	2"x1"	50.80	25.40	73.03	66.68
BPRTL05080381	2"x1-1/2"	50.80	38.10	73.03	66.68
BPRTL06350127	2-1/2"x1/2"	63.50	12.70	79.38	73.03
BPRTL06350191	2-1/2"x3/4"	63.50	19.05	79.38	73.03
BPRTL06350254	2-1/2"x1"	63.50	25.40	79.38	73.03
BPRTL06350381	2-1/2"x1-1/2"	63.50	38.10	79.38	73.03
BPRTL06350508	2-1/2"x2"	63.50	50.80	79.38	73.03
BPRTL07620127	3"x1/2"	76.20	12.70	85.73	79.38
BPRTL07620191	3"x3/4"	76.20	19.05	85.73	79.38
BPRTL07620254	3"x1"	76.20	25.40	85.73	79.38
BPRTL07620381	3"x1-1/2"	76.20	38.10	85.73	79.38
BPRTL07620508	3"x2"	76.20	50.80	85.73	79.38
BPRTL07620635	3"x2-1/2"	76.20	63.50	85.73	79.38
BPRTL10160127	4"x1/2"	101.60	12.70	104.78	92.08
BPRTL10160191	4"x3/4"	101.60	19.05	104.78	92.08
BPRTL10160254	4"x1"	101.60	25.40	104.78	92.08
BPRTL10160381	4"x1-1/2"	101.60	38.10	104.78	92.08
BPRTL10160508	4"x2"	101.60	50.80	104.78	98.43
BPRTL10160635	4"x2-1/2"	101.60	63.50	104.78	98.43
BPRTL10160762	4"x3"	101.60	76.20	104.78	98.43



3A

BS-4825

ISO-SMS

ASME-BPE

STANDARDS

CHEMICAL COMPOSITION

Stainless steel sanitary tubes

RAW MATERIAL CHEMICAL COMPOSITION DETAILS

Grade	Carbon (Max)	Silicon (Max)	Manganese (Max)	Phosphorus (Max)	Sulphur (Max)	Chromium	Molybdenum	Nickel
	C %	Si%	Mn %	P %	S %	Cr %	Mo %	Ni %
304	0.08	0.75	2.0	0.045	0.030	18.00 - 20.00	-	8.00 - 10.50
304L	0.03	0.75	2.0	0.045	0.030	18.00 - 20.00	-	8.00 - 10.50
316	0.08	0.75	2.0	0.045	0.030	16.00 - 18.00	2.00-3.00	10.00 - 14.00
316L	0.03	0.75	2.0	0.045	0.030	16.00 - 18.00	2.00-3.00	10.00 - 14.00
1.4404*	0.03	1.00	2.0	0.045	0.005 - 0.017	16.50 - 18.50	2.00-3.00	10.00 - 15.00
1.4435#	0.03	1.00	2.0	0.045	0.005 - 0.017	17.00 - 19.00	2.50-3.50	12.50 - 15.00

* Controlled Sulphur material || # Low ferrite material || Note: Customized products are also available

CONTROLLED SULPHUR PER ASME-BPE

The widespread use of autogenous (fusion) orbital gas tungsten arc welding (GTAW) in the high-purity, semiconductor and biopharmaceutical industries, is both desirable and necessary to provide for 316L stainless steel with a controlled range of elemental Sulphur. Both the American Society of Mechanical Engineers (ASME) Bioprocessing Equipment Standard (ASME-BPE), which specifies materials for use in bioprocessing equipment, have chosen to specify type 316L stainless steel with

controlled ranges for Sulphur. The ASME BPE standard limits the sulphur concentration to 0.005- 0.017 weight percent

OVERCOMING ROUGHING PROBLEM

When it comes to the stringent process of Biopharmaceutical applications, roughing is a major constraint. We offer EN 1.4435 grade of steel which is of low Ferrite and high Chromium, Nickel and Molybdenum composition. This decreases the chances of roughing in the system.



NON ACCEPTED



NON ACCEPTED



NON ACCEPTED

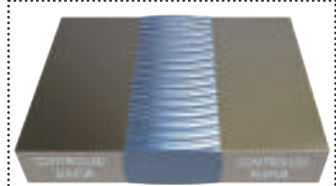

ACCEPTED



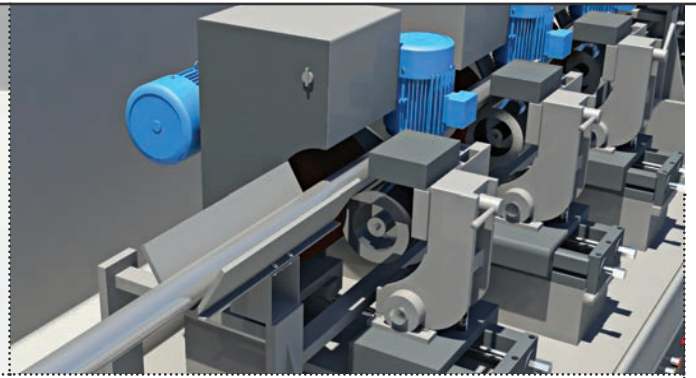

ELECTROPOLISH & MECHANICAL POLISH IN HOUSE CAPABILITY

○ ELECTROPOLISH [ID]

When it comes to critical applications, surface finish is very critical to the tube performance, maintenance cost and service life. The amount of attention given to the surface finish has increased over the years, and rightly so as the impact on the fluid flowing through the tube is very big. The costs and stakes are very high when it comes to losing out a batch due to an issue attributed to the surface finish. We take no chances when

ELECTROPOLISH

Electropolish is an electrolytic process combining electric current and chemicals to remove metal. The peaks of burrs, folds, inclusion and other anomalies of a metal surface are dissolved more quickly than valleys as a result of the greater concentration of current over the protuberances. This electrochemical action produces a smooth surface. This is achieved when all parameters impacting the final electropolished surface are controlled. All our electropolishing is carried out in-house where our trained and experienced quality control team is in full control of the process and its final output. Electropolished tubing is specified for many applications because of the surface smoothness that can be achieved, with fewer sites for trapping impurities. For the industry this means a purer product without danger of bio-film formation in the crevices.

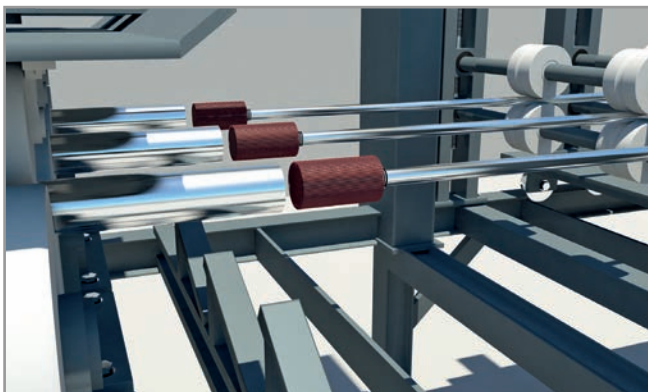

○ MECHANICAL POLISH [OD / ID]

it comes to our tubes. All surface finish process are handled internally where we are in absolute control. Our FINISHING SHOP is fully equipped with all the modern machinery required to execute both Electropolishing and Mechanical polishing processes.



TYPICAL SURFACE FINISH : < 038 μ Ra

MECHANICAL POLISH

The mechanical polish process start with the simultaneous deburring of both ends of a tube. To achieve the desired interior surface finish, an abrasive material, fitted on to a pneumatic polishing head, rotates within the tube continuously. The residue is a fine metal powder that gets removed due to this process. This is finally removed by blowing a clean wipe through the tube before is it sent for visual inspection and finally surface measurement. Typically we can achieve a surface finish up to 0.5 μ Ra with this process. Our finishing shop is equipped with multiple lines of machines. Each machine can polish multiple tubes simultaneously.

TYPICAL SURFACE FINISH : < 0.5 μ Ra

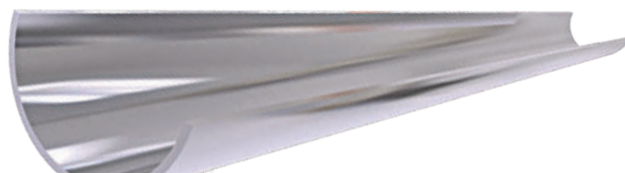

CUSTOMER SUPPORT

We listen to you. By listening we understand. With understanding comes action and speed. Our trained and experienced sales engineers are committed to listen, understand and act on time to ensure that your experience with us always remains pleasant.



SUPPORT

The trust bestowed on us by our customers is an authentication to our commitment to any support required. We are committed to respond to any technical query within a maximum of 48 hours. Our transparent policy means customers can always visit our facility for inspection as required. We also give the option of an inspection prior to the dispatch of the tubes. Customers can inspect the tubes, request for any quality tests and assure themselves before the dispatch of the tubes. This is unique to us and not provided by any of our competitors. A technically qualified and trained sales engineers are always ready to help you with all your technical queries, provide you with application related support in the shortest

possible time. A customer support team are ever ready to help you with the deliveries right till your door step. Our engineers are just a call or email away and ensure your order is processed as smooth as possible. We always keep a buffer stock for most of the tubes. This ensures that you are never delayed on account of the tubes. Unplanned urgent requirement of tubes due to project modifications, site condition related tube re-routing etc. can be serviced using our buffer stock. We also constantly educate customer to make them more aware on the process, manufacturing methodology as well as on site factory tours so that our customers can make an informed decision.

we listen

CUSTOMER LIST

Our customer list is a mix of some of the biggest multinationals and companies that are on the growth path. Most of our supplies are through OEMs that execute various projects leveraging on our quality tubes. A partial list of a few of them is as under.

				
				
				
				
				
				
				... and many more

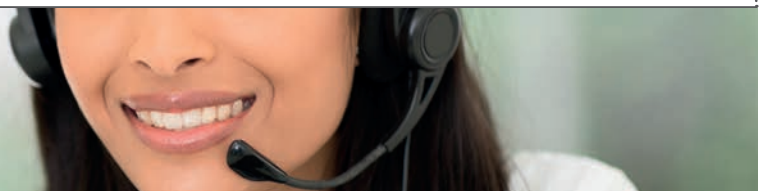



rensa

Positively Smooth



DIN EN ISO 9001 : 2015 Company

PED 2014/68/EU & AD 2000 Merkblatt W0 compliant

3A 33-03, 3A 63-04

ASME BPE certified



Rahul Ferromet & Engg. Pvt. Ltd

Office: 609, Sanket Heights, Vadodara-390020,
Gujarat, India | +91 834 700 0368
Email: marketing@rensatubes.com

Works: Plot No.13 & 14, Jhagadia GIDC, Bharuch, 393110,
Gujarat , India | Email: works@rensatubes.com

